

ARES



Numerically controlled copy router with -90° , 0° , $+90^\circ$ section rotation for working on 3 sides.
Z axis manual down-feed.

The machine is manufactured in accordance with CE regulation.

Overall dimensions:

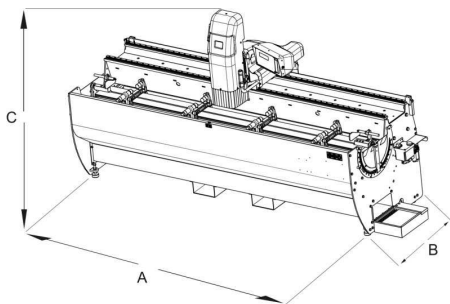

A (mm)	B (mm)	C (mm)	Kg
3200	1200	1800	900

Technical specifications:

- Spindle speed (12.000/6.000 rpm)
- Interpolating numerical control of machining movements on X and Y axes
- Manual lever with adjustable stop rod for the Z axis
- Electronic panel with graphic display to simplify program use and to program a working sequence on 3 faces
- Preset for receiving a working program made up of p.c. in office with program Arescam
- X axis movement with DC motor, high precision reduction unit and belt drive. Y axis movement with DC motor and recirculating ball screw transmission
- Work table with pneumatic rotation from -90° to 0 to +90°
- Work table height: 850 mm
- Micro-drop lubrication system with pure oil
- Work table rotation in complete safety for operators thanks to the selector and the deadman push button control circuit
- Horizontal pneumatic vices movable along the work table (n°4) with double (low and high) operating pressure with safety valves
- Capability for machining intermediates angles with manually adjustable indexed stop
- Tool diameter correction software compensates for sharpening
- Milling sizes: X=2600, Y=250, Z=180
- Three-phase motor: 1,1/0,8 kW – 2800/1400 r.p.m. – 230/400; V 50 Hz
- Working in complete safety thanks to the two deadman levers
- Profile reference stops on right and left ends of the machine
- Profile can be longer than X milling capacity (2600 mm) with the possibility of alternate use of stops on right and left of the machine
- Working pressure: 7 bar
- Air consumption per work cycle: 24 NL (normal litres)
- Chip bin
- Adjustable feet for machine location and anchor brackets
- Set-up for the installation of fumes
- Set-up for loading/unloading with shunter

WORKING CAPACITY

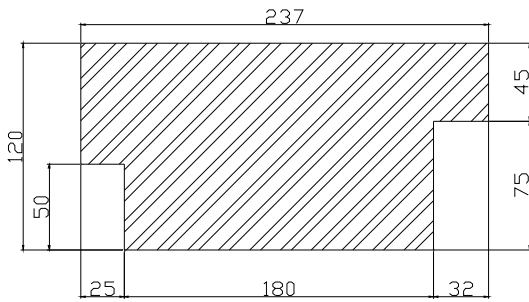

Maximum worktable profile on 2 sides tith tool (diameter 10 mm) – 60 mm height

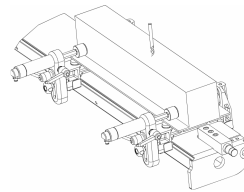

0°

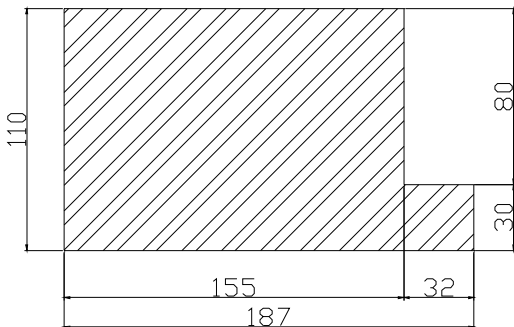

Maximum worktable profile on 3 sides tith tool (diameter 10 mm) – 60 mm height

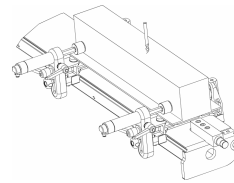

0°

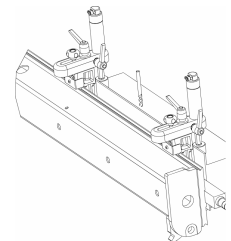

+90°

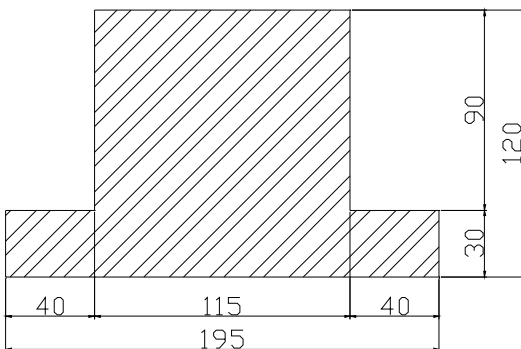

Maximum worktable profile on 1 sides tith tool (diameter 10 mm) – 60 mm height

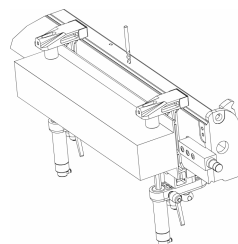

-90°

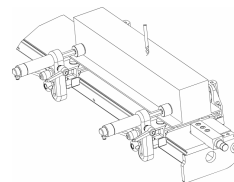

0°

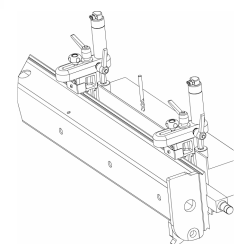

+90°

**Maximum working capacity
AXIS SPECIFICATIONS**

	Axis X	Axis Y	Axis Z
TRAVEL	2600 mm	250 mm	180 mm

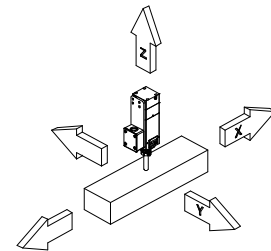

SOFTWARE ARESCAM (on request):

ARESCAM is a CAD/CAM program, operating in Windows ambient, for the graphic designing of the machinings to be executed with the CNC ARES.

Technical specifications:

- 2D graphic representation in CAD ambient of inserted bars and machinings
- Guided introduction of the main machinings (hole, pocket, linear milling, arc, cylindrical hole)
- Parametric machining management
- Simplified management of machining process sequence
- Tool archive management
- Profile and tool archive that can be extended and managed by user
- Management of machining prestored in archive (macro)
- Module for the graphic designing in 3D ambient
- Floppy disk for machine connection

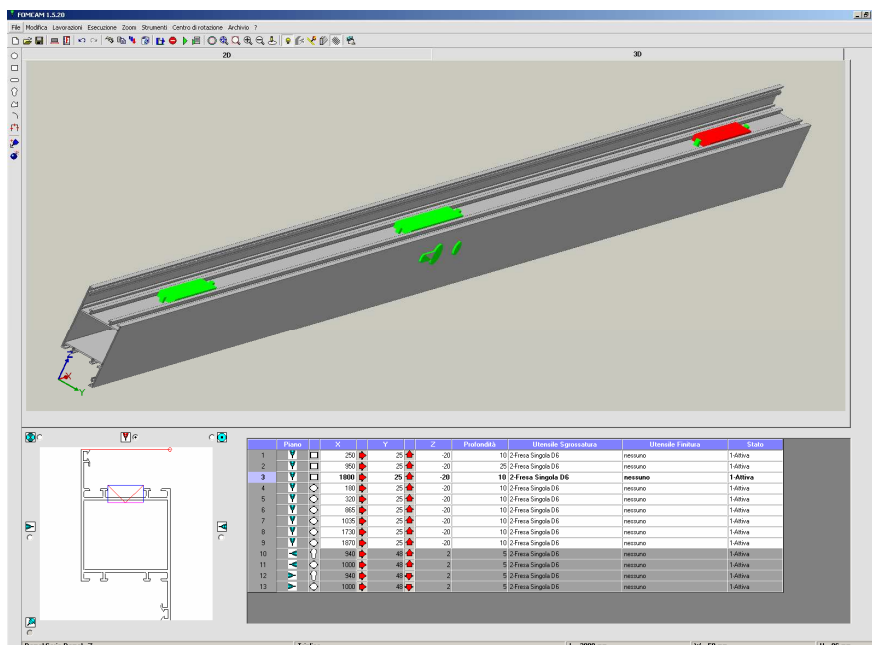

Minimum system requirements for ARESAM installation (not included):

- Pentium 4 processor, 1 GHz or higher
- 256 MBytes RAM.
- At least 10 GBytes free on Hard Disk.
- Windows 2000 with Service Pack 2 and Internet Explorer 6 or Windows XP

STANDARD ACCESSORIES:

n°	Description	Code
1	Diameter 10 mm single edge milling tool with 65 mm length (n°1)	HZ 302740
1	Diameter 5 mm single edge milling tool with 38 mm length (n°1)	HQ 30533
1	Collet for milling bit: diameter 10 mm tang (n°)	DR 75077
1	Collet for milling bit: diameter 8 mm tang (n°)	DR 75088
	Compressed air gun with spiral hose (for machine cleaning)	
	Packing with heat-shrink plastic bag	

OPTIONALS:

Description	Code
Tool rotation inverter kit (3000/12000 r.p.m)	PR 26806
Cooling system by emulsified oil with coolant recovery	PR 26805
Additional clamp	PR 27108
Milling bit 8 mm \varnothing (no.1)	HZ 302946
Milling bit 8 mm \varnothing (no.1)	HZ 303476
Software licence for office "AresCam" program	ZP 26865
Additional "AresCam" licence for office Note: Only with ZP 26865	ZP 26867
Kit for the graphic designing in 3D for "AresCam" Note: Only with ZP 26865	ZB 710212
Kit for the importation of datas for CNC by means of FOM protocol for Note: Only with ZP 26865	ZB 710214
Kit for the importation of datas for CNC by means of a non FOM's protocol Note: Only with ZP 26865	ZB 710238
Bar-code optical reader	PR 26881
Additional charge for special voltage and cycle (Standard motor 230/400V three-phase 50 Hz)	ZG 710135
Additional charge for plant version UL-CSA (The additional charge includes motors with special voltage/measurements unit in inches)	ZG 710136
Milling bit and collets for milling bits (see collets catalogue)	
Crate packing	FC 304447

Packing with heat-shrink plastic bag:

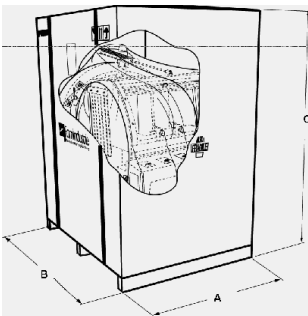

A (mm)	B (mm)	C (mm)	Kg
3200	1200	1800	900

Crate packing:

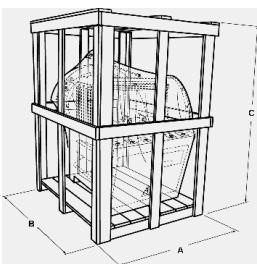

A (mm)	B (mm)	C (mm)	Kg
3500	1400	2050	1138