

PANDA 300 ECHO

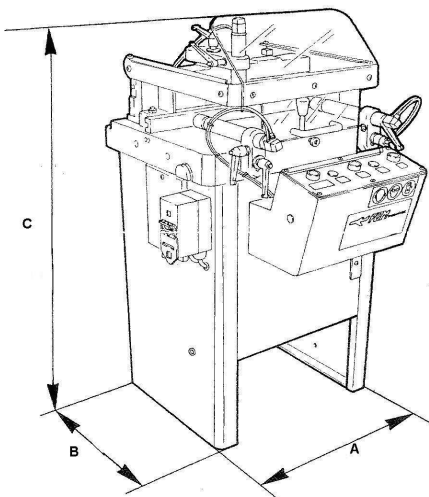

Overall dimensions:



A (mm)	B (mm)	C (mm)	Kg
800	700	1225	150

Technical characteristics:

- Oleopneumatic saw blade advance (adjustable blade exit speed – quick return)
- Blade turning 0° RH/LH
- Prearranged for installation of chip or smoke collectors
- Motor – tungsten carbide saw blade transmission by belt
- Machine and turntable structure in stabilized cast iron
- Turntable rotation on bearings and rollers that guarantees maximum long term precision
- Working pressure: 7 bar
- Saw blade motor, three phase 2 HP (1.47 Kw) – 2800 rpm. eurovoltage 230/400V– 50Hz; 275/480V – 60 Hz.
- Saw blade holding spindle $\varnothing 32$
- Work cycle air consumption 4 NI for automatic blade rise version, 2.1NI for manual blade rise version
- Spray mist blade lubrication system
- Prearranged for installation of chip or smoke collectors

CUTTING DIAGRAM:

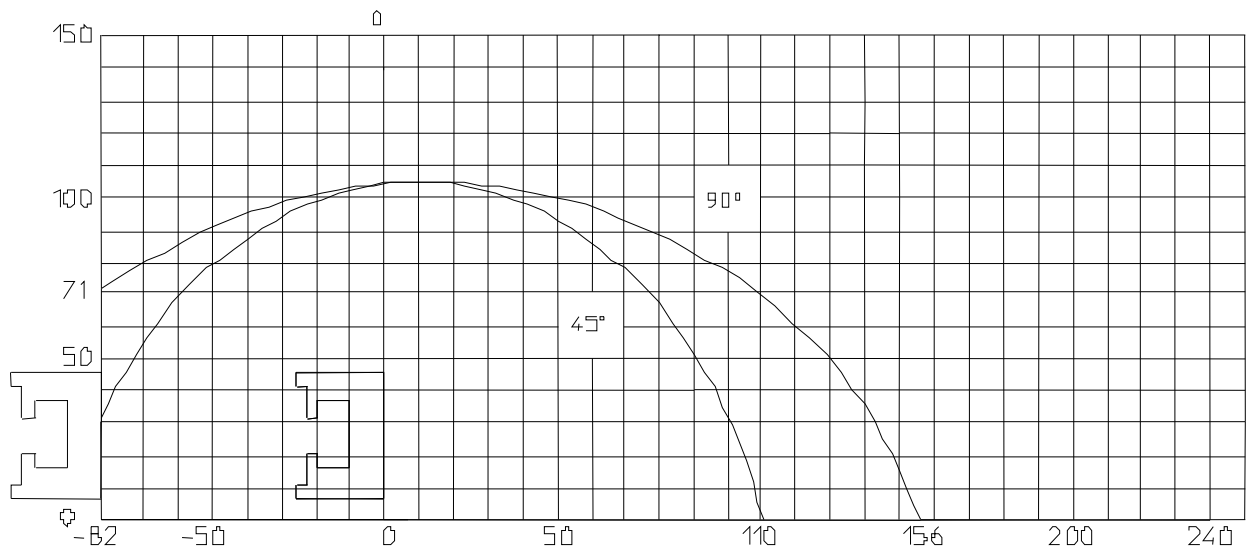

STANDARD ACCESSORIES:

n°	Description
	ø 300 mm tungsten carbide saw blade
	Cutting area guard kit
	Horizontal and vertical vices
	Compressed air gun with spiral hose (for machine cleaning)
	Packing with heat-shrink plastic bag

OPTIONALS:

n°	Description	Code
	Set of camping supports (profile type to be specified)	On estimate
	Micro drop cutting lubrication using pure oil	PR-25279
	Additional vertical vice kit (For Panda MANUAL)	PR-24368
	Additional vertical vice kit (For Panda PNEUMATIC)	PR-24369
	Discharge roller table with length stop: manual, displayed, controlled	
	3 Mt. cutting length	PR-24201
	4,2 Mt. cutting length	PR-25170
	6 Mt. cutting length	PR-25213
	ASSOMAK Loading roller table with vertical roller	
	3 Mt. cutting length	PR-22077
	4,2 Mt. cutting length	PR-25169
	Additional roller for roller tables	PR-22166
	Additional charge for special voltage and cycle (Standard motor 230/400V three-phase 50 HZ)	ZG-79126
	Additional charge for single-phase motor (Standard motor 230 single-phase 50 HZ)	ZG-79127
	Additional charge for plant version UL-CSA (the additional charge includes the plant with cables and special components)	ZG-79158
	Carton pallet packing	FF-71775
	Crate packing	FC-75841

Carton pallet packing with heat-shrink plastic bag:

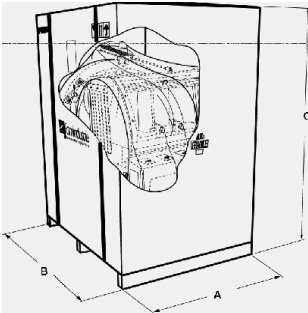

A (mm)	B (mm)	C (mm)	Kg
1070	850	1640	165

Crate packing overall dimensions:

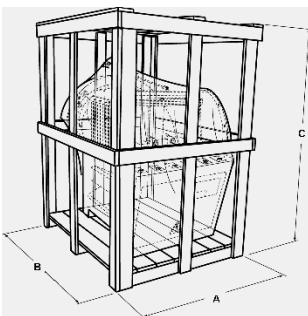

A (mm)	B (mm)	C (mm)	Kg
780	900	1300	200