

DALI' 40 F



CNC Machining centre with 3 controlled interpolating axes.

The Dali 40 F machining centre has been designed to perform boring and milling work on aluminium and PVC profiles. The mechanical specifications of this modern machining centre and of its control system provide economical use in the production of single pieces and limited or medium series with high precision.

1.0 BASIC SPECIFICATIONS

1.1 Structure

The structure consists of a machine bed with a beam that slides across the top of it. Both parts are made of steel and are duly stabilised after each work phase to ensure that there is no interior tension; they are of sufficient size to guarantee stability and precision during machining operations.

1.2 Axis sliding

The axes slide along high precision, robust and reliable linear guideways with recirculating ball blocks that have four points of contact equipped with oil scrapers and with medium/high preloading.

1.3 X – Y – Z Axis drives

The axes are controlled by c.c. motors.
Axes positioning control by encoder.

- A helical rack and pinion system for the X axis (longitudinal)
- Recirculating ball screw ground to high precision and a preloaded worm screw for the Y (transverse) and Z (vertical) axes. The Z axis drive has an electromagnetic brake which is activated if the mains power is switched off for any reason.

1.4 Electrospindle

Designed by Fom Industrie, this electrospindle ensures excellent performance, both at low revolutions as well as at high speed, to satisfy the increasing demands made on the machines in terms of flexibility. It is equipped with 4 kW constant torque, rotation speed of up to 12.000 rpm, adjustable, forced air cooling, ISO 30 DIN 69871 tool coupling and relative presence detecting micro-switch. Front and rear high speed precision bearings ensure strict control of the electrospindle axial and radial stress during the work phases.

1.5 Tool magazine

Located on the carriage in an area protected by a door, it has 5 slots. For the standard version it is possible to have also other solutions.

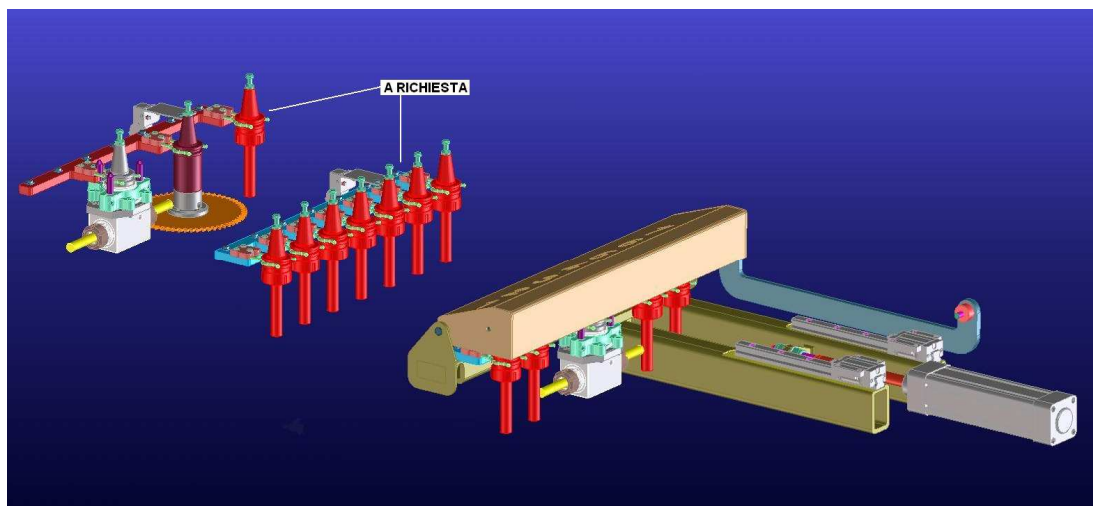

1.6 Working area

This is part of the machine bed and comprises:

- 4 pneumatic vices (expandable) for clamping the profiles. The locking is pneumatic. Movement/positioning is manually controlled with positioning control by means a photocell. The pads supports that clamp the profiles have quick manual positioning. The pads are non-slip and offer vertical adjustment.
- 1 retractable pneumatic stop.

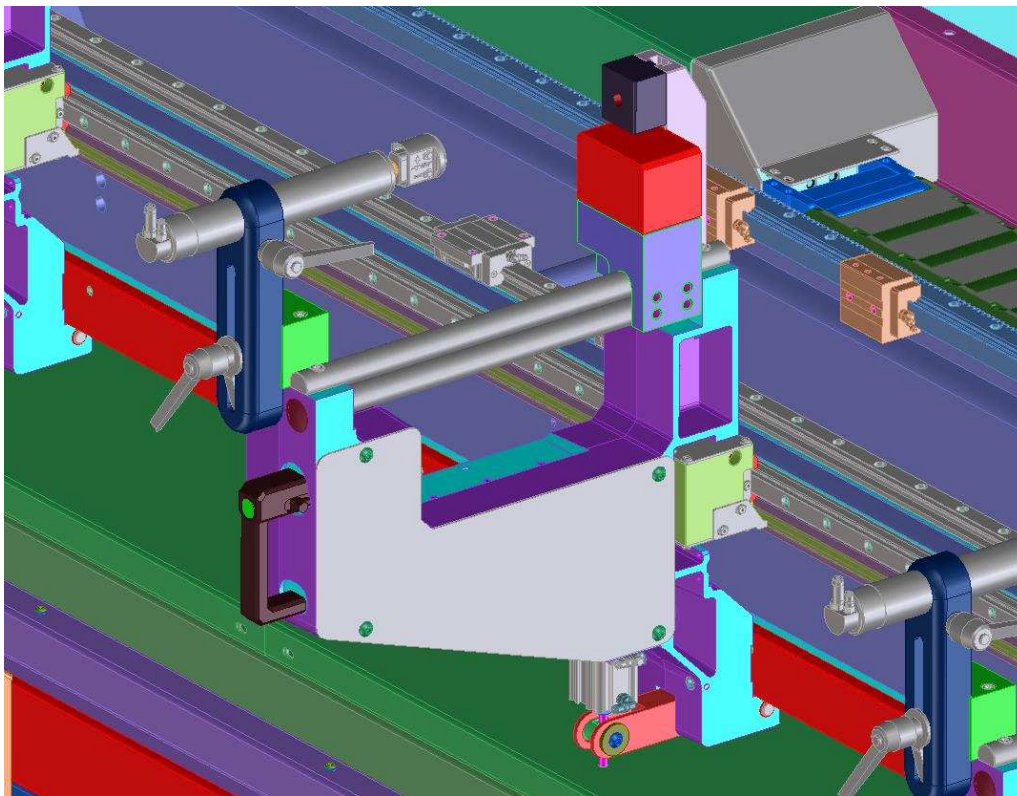

1.7 Command console

It incorporates the user interface made up of a PC, pendant push button strip, Display and alphanumeric keyboard; it includes:

- Connection to laser bar code reader.
- Remote control unit.

1.8 Guards and safety devices

In compliance with the requirements of directive EC 98/37 and successive modifications, there is a barrier all around the machine perimeter fitted with retractable doors and manual opening/closing.

2.0 CONTROL EQUIPMENT

2.1 Omega 200

Made up of:

- Mobile control console
- Extractible shelves (right and left) for mouse support.
- Network to machine electrical cabinet with RJ 45 attachment for the network line
- Network to VISION numeric control for the working programs
- Optical USB mouse
- Pendant push button strip complete of potentiometer for the adjustment of the overfeed of the axes
- Colour display with flat screen TFT 17"
- USB English Keyboard
- Laser gun for bar code reading (available on request)
- Remote unit with display for axis movement (available on request)

PC **PENTIUM 4** comprising:

- Front loading CD-ROM 24X
- Front loading 3,5" 1,44 MB disk drive
- 40 GB Hard disk (7.200 rpm) or higher
- 2 serial ports
- 8 USB ports (6 back, 2 front)
- 512 MB Ram memory
- Ethernet network card: 10/100 Mbps
- ATI Radeon X300 128MB graphic card
- Interior loudspeaker

- Follow programs :
 - **Windows XP Professional SP2.**
 - **FomCam.**
 - **Vision Interface 4** software for managing blocks of manual control and service on line - assistance interface

2.2 FOM CAM



Graphic interface based on the Windows operating system for planning the machining operations and the pieces which automatically generates the CNC program that can be executed by the machining centre.

Program features:

- Easy to learn and easy to use, highly flexible
- 3D simulation of parts, tools and machinings
- Display the piece position on the machine
- Double cell machines management
- Vises and fixtures management
- Machining library for accessories
- DXF Profile Library
- Vise position optimization
- Automatic bar-code recognition
- Integration with ProF2 (window software)
- Cutting line and machining center management
- 5 axis machining

FomCam is the new easy-to-use CadCam solution for the 3D and 2D machining design on profiles. FomCam supports all **FOM machining centers**, the FOM 3, 4 and 5 axis machines and the cutting and machining lines. An intuitive software solution, FomCam was developed in close collaboration with expert machine tool users and manufacturers in the industrial and window manufacturing sectors. FomCam makes possible any kind of machining and ensures the quality of the NC code.

Simplify the working process

It has never been that easy to use a machining center: FomCam's user interface is extremely intuitive as it gives both 2D and 3D simulation options and offers a detailed summary of the machinings added on the part.

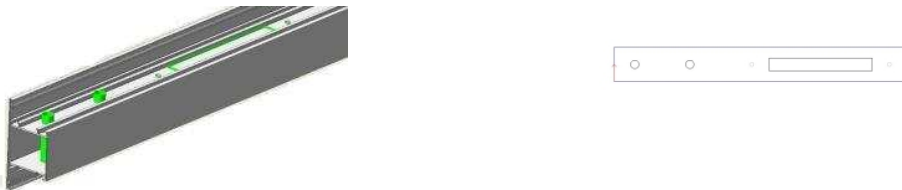

Vise and part positioning in the machine

FomCam automatically generates the CNC codes to be executed on the machine, considering single or double cell, left or right stop, or custom fixture setups for the simultaneous machining of more than one part. FomCam finds automatically the best strategies for vise positioning and simulates the toolpath before the machine starts the job.

Parameterized machinings

The machinings are parameterized. They are easily modified, edited or repeated by changing the numeric data in the model. FomCam applies the update to each machining in real time.

Machining optimizations

To make the machining even faster, the software automatically minimizes the numbers of tool changes and spindle movements saving considerable time.

Libraries

FomCam manages the Profile libraries with 3D and 2D views, the machine's Tool Libraries and the Machining Libraries of the single profiles.

Add the machinings for memorized groups

FomCam lets you proceed rapidly with the machinings for an accessory: just select a code from the accessories list and the X-position on the piece: all machinings referred to the accessory, including the tool data, will be added automatically.

Maximum production control

FomCam directly controls the machining center as it transfers the CNC code and controls its execution. It is not necessary to exit the program while the center is working.

More productivity through automation

The machining cycle starts with the scan of the bar-code on the part. Based on the bar-code data, the center starts the machinings that were defined for this part in the Accessories Library. FomCam also allows to interrupt and re-start the machining list and to view the status info of each part, i.e. the total of repetitions requested and the number of repetitions executed so far.

High-efficiency double cell machinings

Save even more time and avoid production still-stands using the FomCam double cell machining functions. These functions allow to position the vises in one cell while the other cell is working without interruption.

FOMCAM - SIMULATION

Simulate every step of the NC code generation with the intuitive FomCam graphical interface. The visualisations of the components, machinings and tools are 3 dimensional, and the view points can be changed with a simple mouse-click. The 3D views also include different vise setups with multiple components.

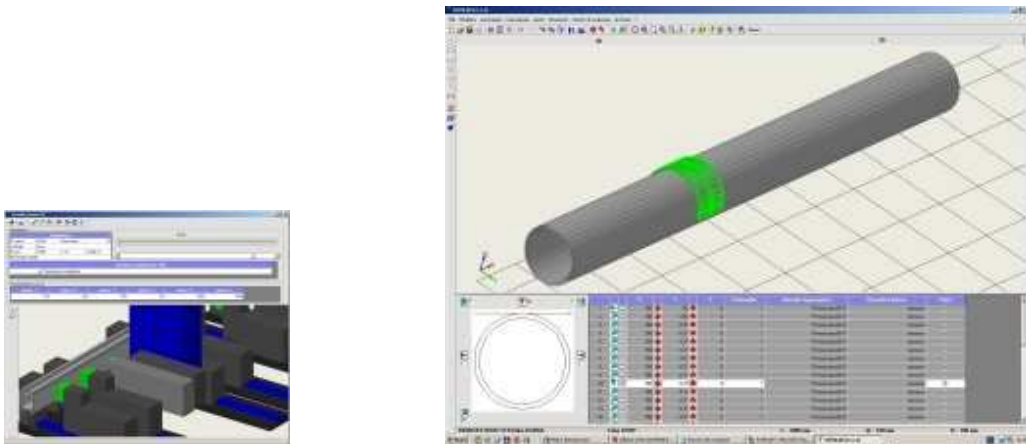

Machining time calculation

Based on the simulation functions, FomCam calculates the exact cycle time of a machining before starting it. FomCam also shows the time schedule within the various machining stages. This calculation is also possible for a list of pieces, including the repetitions, as an estimate of the production time of an entire order.

FOMCAM AND PROF2 INTEGRATION PACKAGE FOR WINDOW AND DOOR MANUFACTURERS

A software solution that enables window and door manufacturers to take advantage of FomCam, as it integrates with the window and door design program ProF2. This integration package will design windows, doors and curtain walls, define the machining strategies and generate the cutting and machining lists. Design the structure and select the profiles with ProF2. Use FomCam to define the machinings for each selected part and the program automatically calculates both the cutting and the machining lists. The optimized cutting list is transmitted to the sawing machine. The sawing machine bar codes and labels the part. The machining center reads the label and executes the machinings as defined by FomCam

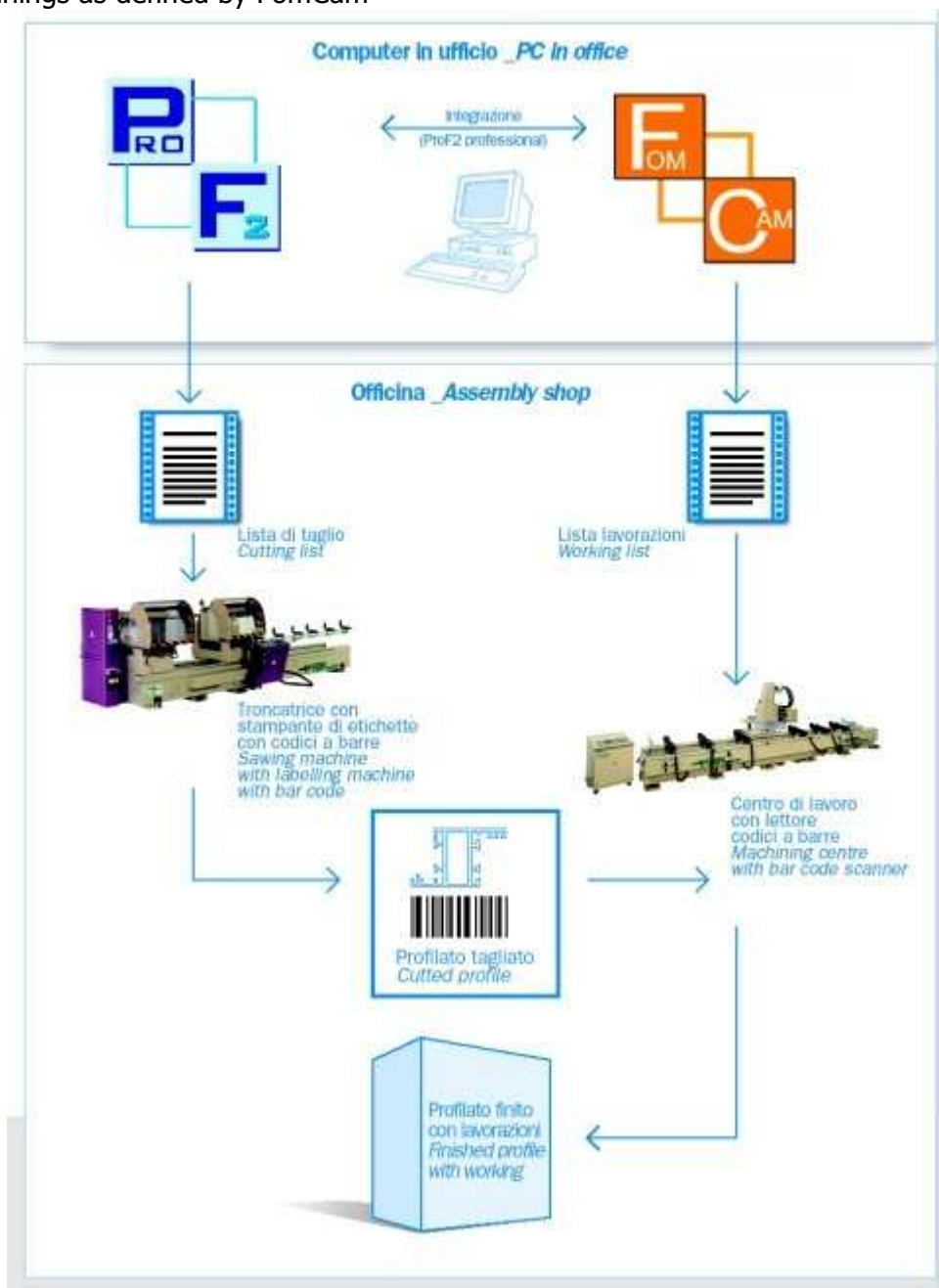

FOMCAM - OPTIONAL MODULES

FomCam also offers a series of optionals based on different needs.

Machinings from DXF

The Machinings from DXF module imports and reads any type of machinings starting from a DXF. This tool allows to create any kind of form for a machining without involving DXF.

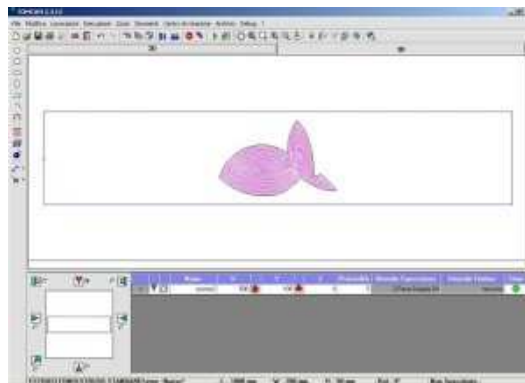

Bar code reader

Reads the bar code and starts the machinings on the selected piece.

Wizards and guided compositions

This module offers some useful features:

In security shutters, it generates automatically the position of the blades. It lets you insert pre-holes into steel machinings. It allows to design bands as a single block and to perform the machinings dividing it into many pieces.

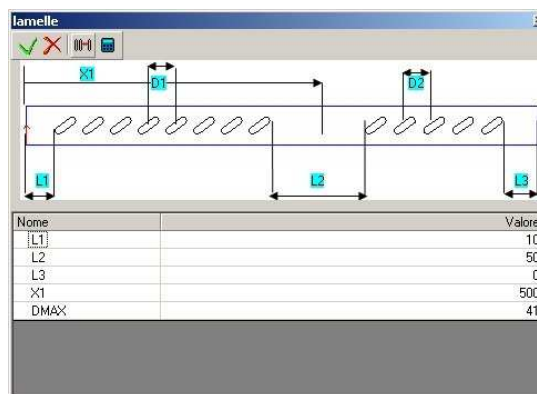

3.0 TURNKEY SYSTEM

FOM INDUSTRIE not only offers its Clients a machine tool, but also a "turnkey" productive system to solve all of the problems involved in production. The company's experience is at the client's disposition to optimise the relationship between machining centre performance and the technological machining requirements, the service relies on:

- A CAD-CAM system for creating a project which provides for piece design, automatic creation of the program and simulation of the machining operations.
- A vast archive of projects created for companies operating in important industrial sectors (automotive, railways, naval, furniture, transport, aeronautic, textile).
- Facilitated contacts with the most important and qualified suppliers of tools and equipment.

4.0 DOCUMENTATION

Every machining centre comes with a printed copy of the following documentation:

- User and maintenance manual, complete with electric and pneumatic diagrams.
- Control unit user's manual.

The manuals are available in Italian and English.

TECHNICAL SPECIFICATIONS	DALI' 40 F
---------------------------------	-------------------

Axis travel			
X axis – longitudinal travel		mm	4.255
Y axis – transverse travel		mm	1.040
Z axis – vertical travel		mm	435
Work capacity			
X axis	longitudinal travel	mm	4.000
Y axis	transverse travel with electrospindle at 90° - 180°	mm	220
Z axis	vertical slag	mm	200

Axis movement			
X axis	Rapid traverse	m/1'	28
	Acceleration	m/s ²	1,00
Y axis	Rapid traverse	m/1'	12
	Acceleration	m/s ²	0,60
Z axis	Rapid traverse	m/1'	6
	Acceleration	m/s ²	0,25

Machine accuracy		
Positioning		± 0,15
Repeatability		± 0,10

Electrospindle			
Cone			ISO 30 DIN 69871
Power 4 Kw (s1)	Max. torque	Nm	6,5
	Max. rotation speed	rpm	12.000
Tool magazine			
Tool replacement time		sec.	14
Number of tools possible		N°	5
Maximum tool weight		Kg.	6
Dimensions			
Length		mm	5.591
Width		mm	2.051
Height		mm	2.341
Weight		Kg	2.700

Overall dimensions machine:

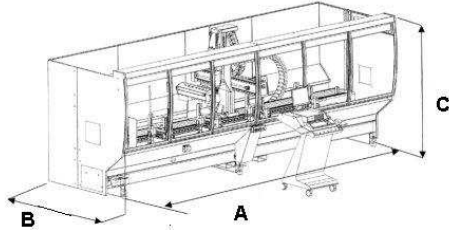

	A (mm)	B (mm)	C (mm)	Kg
DALI 40F	5.591	2.051	2.341	2.700
DALI 70F	8.765	2.051	2.341	4.200

STANDARD ACCESSORIES:

Description
Electrospindle FOM 4Kw 12.000 rpm (ISO 30)
7 position tool magazine. (ISO 30)
Note: <u>No housing</u> of single/double tool angular unit and blade-holder cone
No.4 pneumatic vices with positioning through carriage
LH receding pneumatic stop
Tool micro-drop lubrication by pure oil
Chip bin
Guard with receding frontal doors with manual opening
Set up for forced evacuation of fumes collectors
Electronic equipment "Vision"
PC+monitor+Operating System in English
Control Console
Software licence for FOMCAM program

SPECIAL VOLTAGE MOTORS / PLANET VERSION UL-CSA:

Description	Code
Additional charge for special voltage and cycles (external transformer) (Standard motor 380-460V three-phase 50/60Hz)	ZG-79248
Additional charge for electrical equipment in compliance with UL-CSA standards. (The additional charge includes the electrical equipment with cables and special components/measurement unit in inches)	ZG-79251

OPTIONALS:

ELECTROSPINDLE:

Description	Code
Surcharge for FOM 4KW 17.000 r.p.m. electrospindle (ISO 30) For Dali 40/70F	PR-27176

TOOL MAGAZINE:

Description	Code
7 position tool magazine for cones (ISO30) (Note: in replacement to the standard magazine)	PR-27254
1-position tool magazine (ISO 30) + single-/double- tool angular unit for bar machining on the front/posterior face and blade-holder cone (Note: in replacement to the standard magazine) Note: max. diameter blade 200mm	PR-27255

OPTIONALS:

Description	Code
Additional standard clamps (manual positioning) (No.2) Note: Dali 40F max 2 additional clamps	PR-27245
Additional standard clamps (manual positioning) (No.2) Note: Dali 70F max 4 additional clamps	PR-27246
Surcharge for transforming the standard clamps into clamps with positioning through carriage. Note: clamp positioned by means of the head	PR-27061
Additional clamps with positioning through carriage (No.2) Note: Only with PR-27061 Note: Dali 40F max 2 additional clamps	PR-27247
Additional clamps with positioning through carriage (No.2) Note: Only with PR-27061 Note: Dali 70F max 4 additional clamps	PR-27248
Surcharge for transforming the standard clamps into clamps with independent positioning	PR-27063
Surcharge for transforming the standard clamps into clamps with independent positioning	PR-27249
Additional clamps with independent positioning (No.2) Note: Only with PR-27063 Note: Dali 40 max 2 additional clamps	PR-27250
Additional clamps with independent positioning (No.2) Note: Only with PR-27249 Note: Dali 70 max 4 additional clamps	PR-27251
Dual station Note: At least No. 2 additional clamps required.	PR 27065
Dual station Note: At least No. 2 additional clamps required.	PR-27239
Surcharge for automatic opening/closing of the frontal doors	PR-27177
Surcharge for automatic opening/closing of the frontal doors	PR-27240
RH profile stop kit for long pieces machining or for two pieces without dual station Note: accessory not available if dual station is standard	PR-27066
Flowdrill kit! Note: Lubricating oil not included	PR-27067
Micro-drop blade lubrication system for double tool angle head machining	PR-27069
Cooling system by emulsified oil with coolant recovery Note: Accessory not available if PR-27072 or PR-27241 or PR-27242 or PR-27068 is standard	PR-27071
Chip conveyor belt. Note: Accessory not available PR-27068 or PR-27071 is standard	PR-27241
Chip conveyor belt. Note: Accessory not available if PR-27071 is standard	PR-27242
Evacuatore trucioli a tappeto. Nota: Accessorio non disponibile se presente PR-27071 o PR-27241 Chip conveyor belt. Note: Accessory not available if PR-27071 or PR-27241 are is standard	PR-27068
Forced/timed lubricating system for linear guideways and ball screws	PR-27243
Machine handling kit for container	PR-27132

SOFTWARE:

Description	Code
Software licence for office FOMCAM program	ZP-26866
Additional FOMCAM licence for office NOTE: Only with ZP-26866	ZP-26868
Kit for the insertion of geometries 'defined by the user' and import of drawings in DXF format for FOMCAM	ZB710210
Kit for the graphic designing in 3D for FOMCAM	ZB710213
Kit for the importation of datas for CNC by means of FOM protocol for FOMCAM	ZB710214
Kit for the importation of datas for CNC by means of a non FOM's protocol	ZB710238
Software licence for tapping cycle.	ZB-78091
Kit for tele-service with analogue line. Note: it includes modem and PC-anywhere (See page 7)	PR-26264
Bar-code optical reader and relevant software for the management of the working lists with module for data importation for CNC by means of Fom protocol for FOMCAM. (ZB710214)	PR-26895
Bar-code optical reader and relevant software for the management of the working lists with module for data importation for CNC by means of a non-Fom's protocol per FOMCAM. (ZB710238)	PR-27042
Wireless bar-code optical reader and relevant software for the management of the working lists with module for data importation for CNC by means of FOM protocol for FOMCAM. (ZB710214)	PR-27302
Wireless bar-code optical reader and relevant software for the management of the working lists with module for data importation for CNC by means of non-Fom's protocol for FOMCAM. (ZB710238)	PR-27303
Software licence for "Clock", module for times calculation for FOMCAM. (see pag. 10)	ZB710453
Licenza d'uso programma "Wizard", modulo per FOMCAM	ZB710598
Software licence for "Production", cutting lists management	ZP710562
Modulo lavorazione Production ed integrazione con FOMCAM	ZP710563

