

SPEEDY WORK

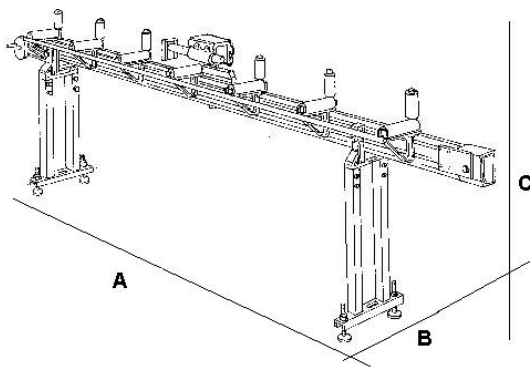

Roller table with manual length stop positioning



	A(mm)	B(mm)	C(mm)	Kg
m. 3	310	3.100	1.170	50
m. 4,2	310	4.300	1.170	73

Technical characteristics:

- Minimum cut 0 mm
- Manual length stops kit
- Loading capacity per linear metre 3 Kg
- Width of bar resting surface 200 mm
- Patented length stop with sliding surface under the work table, to give constant reference under all working conditions

STANDARD ACCESSORIES:

Description
Loading capacity: Kg. 3 per meter
Manual length stop kit
Plastic rollers
Carton packing

STANDARD ACCESSORIES:

Description	Code
Additional manual length stop device	PR-20327
Additional roller for roller table	PR-22166

PACKING

Crate packing overall dimensions:

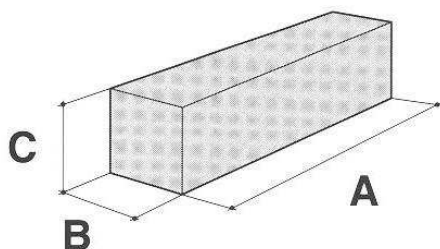

	A (mm)	B (mm)	C (mm)	Kg
m. 3				
m. 4,2				