

PEGASO 2

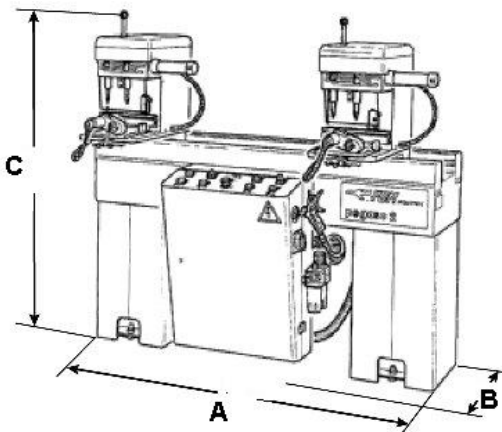

Double unit electro-pneumatic drilling machine

Overall dimensions:



| | A (mm) | B (mm) | C (mm) | Kg |
|-----------------------|--------|--------|--------|-----|
| bed m. 1,6 | 1550 | 800 | 1350 | 330 |
| bed m. 3 | 3000 | 800 | 1350 | 450 |

Technical characteristics:

- Automatic drill bit downstroke with rapid approach
- First and second mobile head
- Pneumatically adjusted drilling c/c distance with two preset positions
- Quick drilling axis distance adjustment on bar with mechanical stops in 8 preset positions
- Possibility of drilling with different distance first and second head axes; max 60mm
- Drilling c/c distance min=25mm, max = 180mm.
- Cutting lubrication by atomizer
- N° 2 three phase motors 0.75 KW (1Hp), 900 rpm. eurovoltage 230/400V– 50Hz; 275/480V – 60 Hz.
- Spindle rotation speed 1800 rpm.
- Bit shank Ø 10mm
- Vertical spindle stroke 80mm
- Max. profile clamping dimensions 110 x 120 h mm

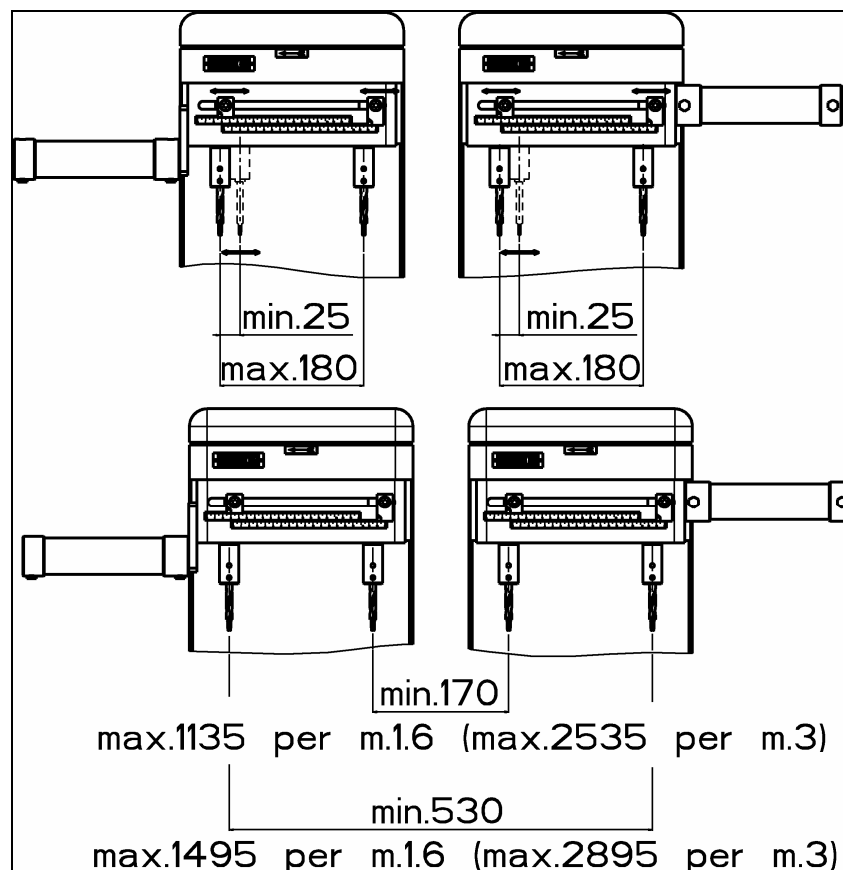

STANDARD ACCESSORIES:

| N° | Description | Code |
|----|-------------------------------|----------|
| 4 | Double diameter drill 6/12 mm | HZ 37305 |
| | Horizontal vice | |

OPTIONALS:

| Description | Code |
|---|-------------|
| Vice jaw extension 280 mm (Rh/Lh) with 1 receding stop | PR-22626 |
| Additional receding stop | PR-24240 |
| Additional stop ledge | PR-24322 |
| Micro-drop pure oil blade lubrication system | PR-25211 |
| Collet-holder spindle kit \varnothing 5/7 mm | PR-22618 |
| Additional vertical drilling unit complete | On estimate |
| Additional charge for special voltage and cycle Note: For single head (Standard motor 230/400V three-phase 50 Hz) | ZG-79126 |
| Additional charge for single-phase motor Note: For single head (Standard motor 230 single-phase 50 Hz) | ZG-79127 |
| Additional charge for plant version UL-CSA (The additional charge includes motors with special voltage/measurement unit in inches) | ZG-79158 |

PACKING

| Description | Code |
|---------------|----------|
| Crate packing | FC-72842 |
| Crate packing | FC-72843 |

Crate packing overall dimensions:

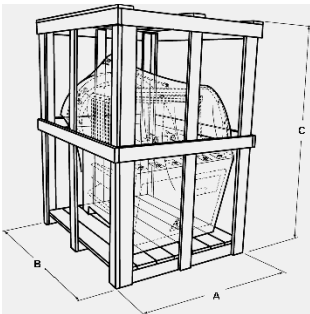

| | A (mm) | B (mm) | C (mm) | Kg |
|-----------------------|--------|--------|--------|-----|
| bed m. 1,6 | 3150 | 900 | 1500 | 453 |
| bed m. 3 | | | | |